

DEFI

STRUCTURAL FIBERGLASS

GRATING PRODUCTS

FRP GRATINGS / FRP STRUCTURAL SHAPES / DESIGN - FABRICATION

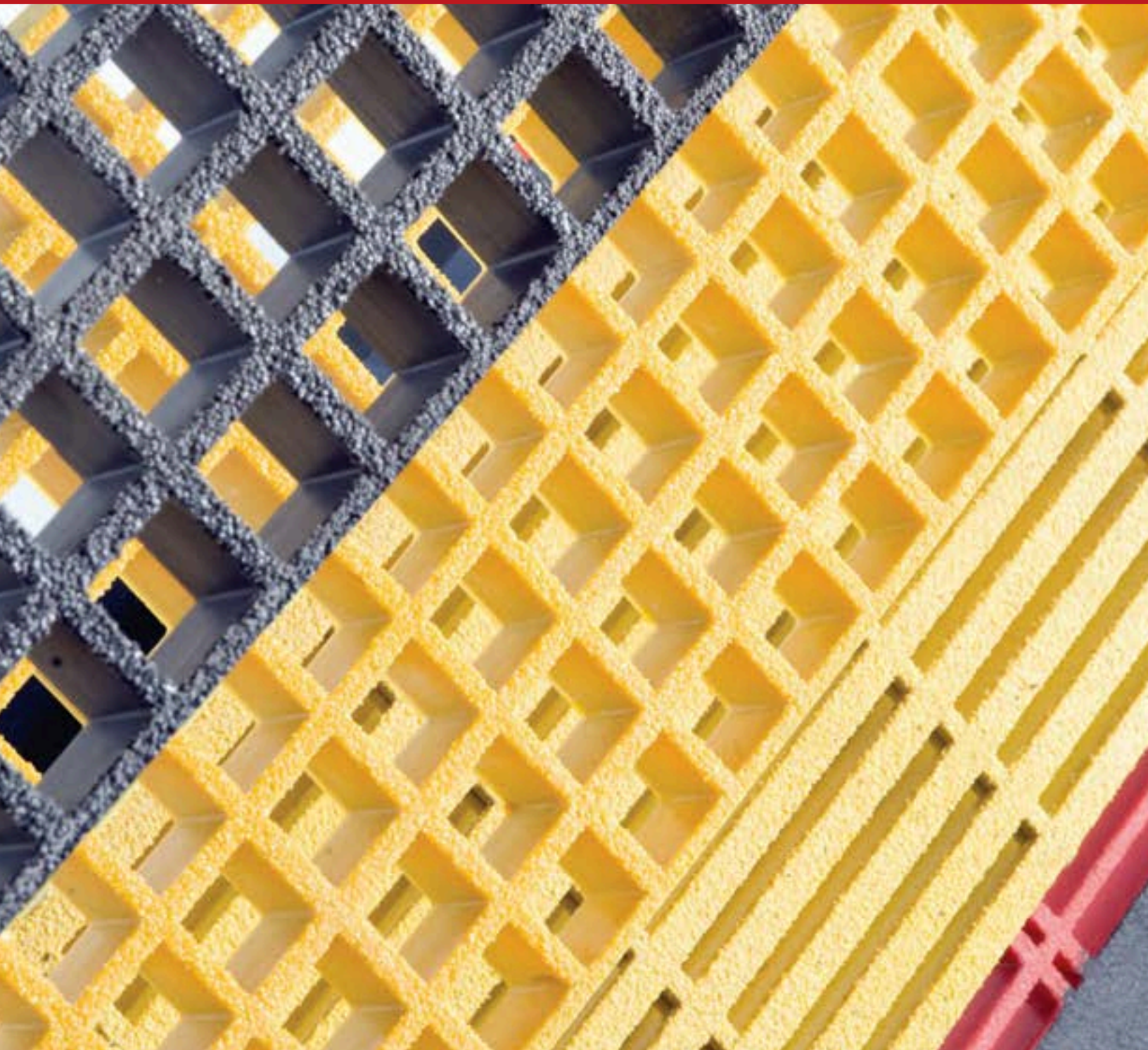

DEFI

STRUCTURAL FIBERGLASS

www.defifiberglass.com

(800) 949-3665

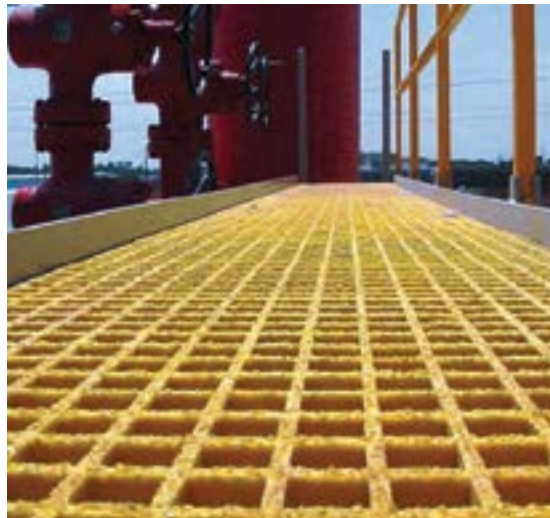

APPLICATIONS

- Floor systems
- Walkways
- Work platforms
- Stairs
- Ramps
- Trench covers
- Catwalks

FEATURES

- Corrosion resistant
- Slip-resistant gritted top surface
- Strong yet lightweight
- Low coefficient of expansion and contraction

BENEFITS

- Reduced maintenance and replacement costs
- Enhanced workplace safety
- Reduced installation costs
- Dimensionally stable in many environments

STRONG, LIGHTWEIGHT AND CORROSION-RESISTANT

Want the strength of steel without the weight? Our fiberglass-reinforced polymer (FRP) grating products have the advantage. Our grating is corrosion-resistant, it's fire-retardant, and it has low conductivity. It's available with anti-slip coating for worker safety. And it's easy to install with standard tools.

Whether you simply need grating panels or a complete FRP system with handrails, stairs and platforms, we have the solution to match. In addition to our products, we offer in-house design, engineering and fabrication capabilities to meet your project needs.



Molded Grating

Proven corrosion resistance is just one of the benefits of our molded grating. It's strong, lightweight and performs reliably for years, even in extreme conditions. Top surface options also provide excellent slip resistance for worker safety.

Long Service Life

The high resin-to-glass ratio (approximately 65% resin to 35% glass by weight) provides excellent service life, even in the most demanding applications.

Less Waste

Interwoven square mesh construction provides bi-directional strength, so you can cut grating to fit and make the most efficient use of each panel.

Available Resin Systems

Molded grating is available in three resin systems, each providing different levels of corrosion protection. All three resin systems meet Class 1 Flame Spread Rating per ASTM E-84 test standards.

GP: A general-purpose orthophthalic polyester resin system that offers good corrosion resistance at an economical price. Standard colors: Yellow and Light Gray

IFR: A premium-grade isophthalic polyester resin system that provides excellent corrosion protection. Standard colors: Green, Yellow, Dark Gray and Light Gray

VFR: A vinylester resin system that provides the highest level of corrosion protection. Standard colors: Orange and Dark Gray

Available Top Surfaces

Molded grating is available in square or rectangular mesh patterns with either Meniscus or Grit-Top slip-resistant top surfaces.

Grit-Top: Quartz grit anti-slip surface

Meniscus: Concave, half-moon cross section with no grit

UV Inhibitor
Fire Retardant
Polyester or
Vinylester Resin

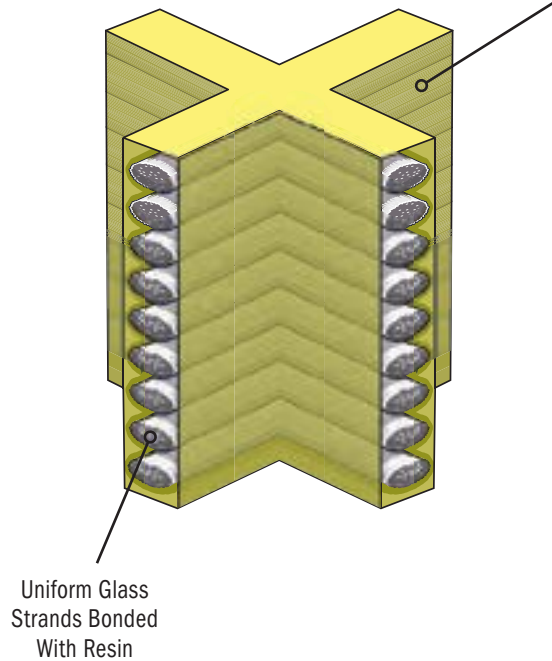

Available Grid Dimensions

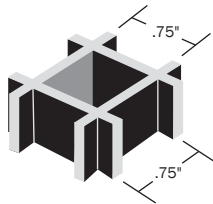

**1" or 1½" thick,
¾" x ¾" Square Grid**

Bearing bars 0.25" thick
Open area of 69%

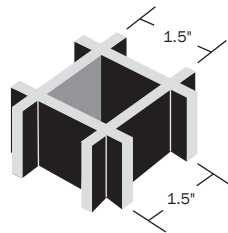

**1" or 1½" thick,
1½" x 1½" Square Grid**

Bearing bars 0.25" thick
Open area of 69%

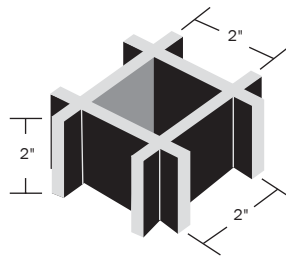

**2" thick,
2" x 2" Square Grid**

Bearing bars 0.3125" thick
Open area of 71%

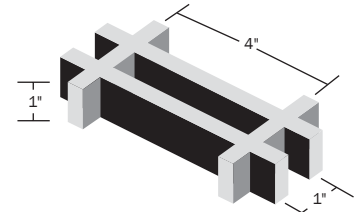

**1" thick,
1" x 4" Rectangular Grid**

Bearing bars 0.25" thick
Open area of 68%

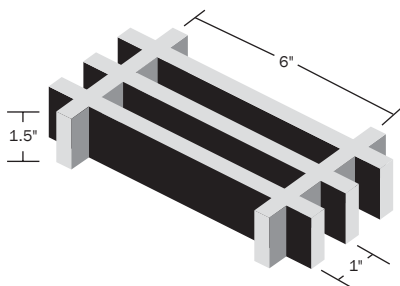

**1½" thick,
1" x 6" Rectangular Grid**

Bearing bars 0.6" thick
Open area of 38%

Available Panel Sizes*

1" x ¾" x ¾" (Square)	4' wide x 12' long
1½" x ¾" x ¾" (Square)	4' wide x 12' long
1" x 1½" x 1½" (Square)	3' wide x 10' long / 4' wide x 8' long / 4' wide x 12' long
1½" x 1½" x 1½" (Square)	3' wide x 10' long / 3' wide x 12' long / 4' wide x 12' long
2" x 2" x 2" (Square)	4' wide x 12' long / 5' wide x 12' long
1" x 1" x 4" (Rectangular)	12' wide x 4' long / 10' wide x 3' long
1½" x 1" x 6" (Rectangular)	4' wide x 12' long

*Note: Not all panel sizes are stocked in every resin series and color. Check website for availability.

Molded Grating Load and Deflection Data

CONCENTRATED LOAD

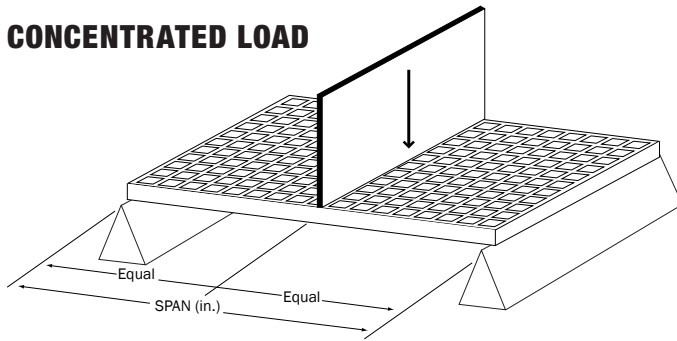

UNIFORM LOAD

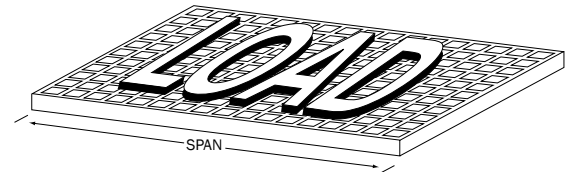

1. The following tables were developed in accordance with the test method developed by the Fiberglass Grating Manufacturers Council (FGMC) of the American Composites Manufacturers Association (ACMA) for the Fiberglass Grating Standard.
2. The designer should not exceed MAXIMUM RECOMMENDED load at any time. MAXIMUM LOAD represents a 4:1 factor of safety on ULTIMATE CAPACITY. ULTIMATE CAPACITY represents MAX LOAD observed at initial fracture.
3. Walking loads for maintenance traffic are typically a live load of 50 PSF. Deflections for worker comfort are typically limited to 0.375" (3/8") or SPAN divided by 120 under full live load. For a firmer feel under full live load or a line load 250 lb/ft of width, limit deflections to 0.25" (1/4") or SPAN divided by 200.
4. The loads represented are for STATIC LOAD CONDITIONS at ambient temperature. Deflections for impact loads or dynamic loads will MULTIPLY the deflections shown by 2. Long term loads will result in added deflection due to creep in the material and will require higher factors of safety to ensure acceptable performance.
5. Deflections are limited to 0.5" (1/2") as recommended by the Fiberglass Grating Manufacturers Council of the American Composites Manufacturers Association.

1" x 1" x 4"
Rectangular Grid
1" Thick
68% Open

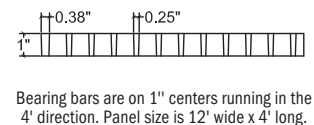
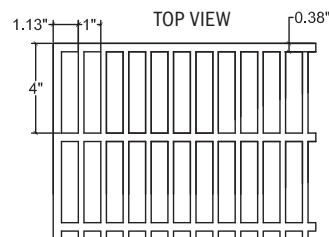

Span (inches)	CONCENTRATED LOAD in lb/ft of width								Max Load (lb/ft)	Apparent EI x 10 ⁶ (lb-in ²)
	50	100	150	200	250	500	1000	2000		
12	0.004	0.008	0.012	0.016	0.020	0.040	0.079		1834	0.45
18	0.012	0.024	0.036	0.049	0.061	0.122	0.243		1419	0.50
24	0.028	0.056	0.083	0.111	0.139	0.278	0.555		961	0.52
30	0.053	0.107	0.160	0.213	0.266	0.533			769	0.53
36	0.090	0.181	0.271	0.362	0.452				641	0.54
42	0.138	0.276	0.413	0.551	0.689				549	0.56
46	0.178	0.355							501	0.57

Span (inches)	UNIFORM LOAD in lb/ft ²								Max Load (lb/ft ²)	Apparent EI x 10 ⁶ (lb-in ²)
	50	100	150	200	250	500	1000	2000		
12	0.002	0.005	0.007	0.010	0.012	0.025	0.050	0.099	3668	0.45
18	0.011	0.023	0.034	0.046	0.057	0.114	0.228		1892	0.50
24	0.035	0.069	0.104	0.139	0.174	0.347			961	0.52
30	0.083	0.167	0.250	0.333	0.416				615	0.53
36	0.170	0.339	0.509	0.679					427	0.54
42	0.301	0.603							314	0.56
46	0.430								287	0.57

Properties Per Foot of Width	# of Bars	Load Bar Width	Bar Centers	Weight/sq ft
A = 2.69 in ² I = 0.22 in ⁴ S = 0.45 in ³	12	0.25"	1"	2.61

1" x 1½" x 1½"
Square Grid
1" Thick
69% Open

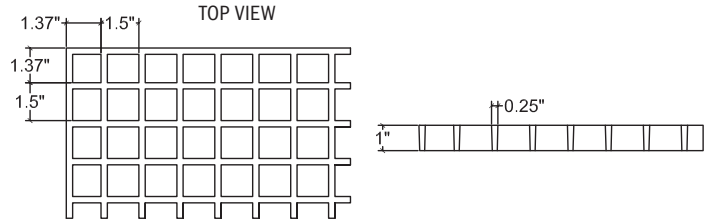

Span (inches)	CONCENTRATED LOAD in lb/ft of width								Max Load (lb/ft)	Apparent EI x 10 ⁶ (lb-in ²)
	50	100	150	200	250	500	1000	2000		
12	0.006	0.011	0.017	0.023	0.029	0.057	0.114		1189	0.31
18	0.018	0.035	0.053	0.071	0.089	0.177			934	0.34
24	0.040	0.080	0.120	0.160	0.199	0.399			668	0.36
30	0.076	0.152	0.228	0.304	0.380				534	0.37
36	0.128	0.256	0.384	0.512	0.640				360	0.38

Span (inches)	UNIFORM LOAD in lb/ft ²								Max Load (lb/ft ²)	Apparent EI x 10 ⁶ (lb-in ²)
	50	100	150	200	250	500	1000	2000		
12	0.004	0.007	0.011	0.014	0.018	0.036	0.071	0.143	2378	0.31
18	0.017	0.033	0.050	0.066	0.083	0.166	0.332		1245	0.34
24	0.050	0.100	0.150	0.199	0.249	0.498			668	0.36
30	0.119	0.237	0.356	0.475	0.593				427	0.37
36	0.240	0.480							240	0.38
42	0.431								205	0.39

Properties Per Foot of Width	# of Bars	Load Bar Width	Bar Centers	Weight/sq ft
A = 1.79 in ² I = 0.15 in ⁴ S = 0.30 in ³	8	0.25"	1.5"	2.5

1½" x 1½" x 1½"
Square Grid
1½" Thick
68% Open

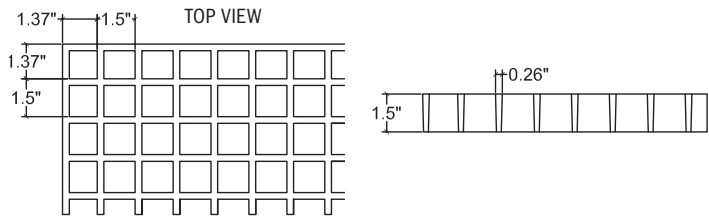

Span (inches)	CONCENTRATED LOAD in lb/ft of width								Max Load (lb/ft)	Apparent EI x 10 ⁶ (lb-in ²)
	50	100	150	200	250	500	1000	2000		
12	0.002	0.005	0.007	0.009	0.011	0.023	0.045	0.090	2041	0.80
18	0.005	0.011	0.016	0.022	0.027	0.055	0.109		1360	1.11
24	0.012	0.023	0.035	0.046	0.058	0.115	0.230		1021	1.25
30	0.021	0.043	0.064	0.086	0.107	0.214			816	1.31
36	0.036	0.072	0.108	0.144	0.180	0.360			680	1.35
42	0.056	0.113	0.169	0.225	0.282	0.563			583	1.37
48	0.084	0.167	0.251	0.334	0.418				510	1.38
54	0.119	0.238	0.357	0.476	0.594				453	1.38

Span (inches)	UNIFORM LOAD in lb/ft ²								Max Load (lb/ft ²)	Apparent EI x 10 ⁶ (lb-in ²)
	50	100	150	200	250	500	1000	2000		
12	0.001	0.003	0.004	0.006	0.007	0.014	0.028	0.057	4082	0.80
18	0.005	0.010	0.015	0.021	0.026	0.051	0.103		1813	1.11
24	0.014	0.029	0.043	0.058	0.072	0.144	0.288		1021	1.25
30	0.033	0.067	0.100	0.134	0.167	0.334			653	1.31
36	0.067	0.135	0.202	0.270	0.337				453	1.35
42	0.123	0.246	0.370	0.493	0.616				333	1.37
48	0.209	0.417	0.626						255	1.38
54	0.334	0.669							201	1.38

Properties Per Foot of Width	# of Bars	Load Bar Width	Bar Centers	Weight/sq ft
A = 2.73 in ² I = 0.49 in ⁴ S = 0.65 in ³	8	0.25"	1.5"	3.94

2" x 2" x 2"
Square Grid
2" Thick
71% Open

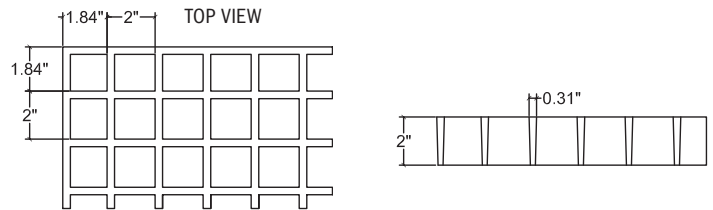

Span (inches)	CONCENTRATED LOAD in lb/ft of width								Max Load (lb/ft)	Apparent EI x 10 ⁶ (lb-in ²)
	50	100	150	200	250	500	1000	2000		
12	0.001	0.002	0.003	0.004	0.005	0.010	0.020	0.040	4632	1.80
18	0.003	0.006	0.009	0.011	0.014	0.029	0.057	0.114	3088	2.13
24	0.006	0.012	0.018	0.024	0.030	0.060	0.120	0.240	2316	2.40
30	0.011	0.023	0.034	0.045	0.056	0.113	0.225		1853	2.50
36	0.019	0.038	0.057	0.076	0.095	0.191	0.381		1544	2.55
42	0.030	0.059	0.089	0.118	0.148	0.296	0.591		1323	2.61
48	0.043	0.087	0.130	0.174	0.217	0.435			1158	2.65
54	0.061	0.122	0.183	0.244	0.305	0.610			1029	2.69
60	0.083	0.166	0.249	0.332	0.415				926	2.71

Span (inches)	UNIFORM LOAD in lb/ft ²								Max Load (lb/ft ²)	Apparent EI x 10 ⁶ (lb-in ²)
	50	100	150	200	250	500	1000	2000		
12	<0.001	0.001	0.002	0.003	0.003	0.006	0.013	0.025	9264	1.80
18	0.003	0.005	0.008	0.011	0.013	0.027	0.053	0.107	4117	2.13
24	0.008	0.015	0.023	0.030	0.038	0.075	0.150	0.300	2316	2.40
30	0.018	0.035	0.053	0.070	0.088	0.176	0.352		1482	2.50
36	0.036	0.071	0.107	0.143	0.179	0.357			1029	2.55
42	0.065	0.129	0.194	0.259	0.323	0.647			756	2.61
48	0.109	0.217	0.326	0.435	0.543				579	2.65
54	0.171	0.343	0.514	0.686					457	2.69
60	0.259	0.519							371	2.71

Properties Per Foot of Width	# of Bars	Load Bar Width	Bar Centers	Weight/sq ft
A = 3.12 in ² I = 1.03 in ⁴ S = 1.03 in ³	6	0.31" (5/16")	2"	4.51

1" x 3/4" x 3/4"
Square Grid
1" Thick
44% Open

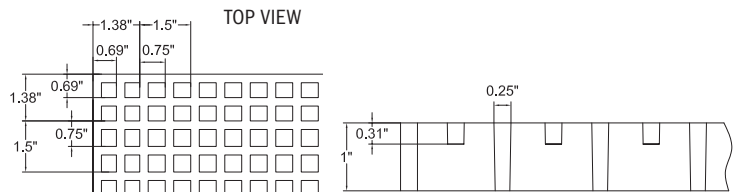

Span (inches)	CONCENTRATED LOAD in lb/ft of width								Max Load (lb/ft)	Apparent EI x 10 ⁶ (lb-in ²)
	50	100	150	200	250	500	1000	2000		
12	0.003	0.006	0.012	0.031	0.045	0.059	0.089	0.120	1239	0.599
18	0.012	0.024	0.049	0.125	0.188	0.254	0.389		826	0.486
24	0.029	0.057	0.116	0.295	0.456	0.580			620	0.494
30	0.059	0.116	0.233	0.605					496	0.478
36	0.088	0.175	0.360						413	0.549
42	0.171	0.346							354	0.448
48	0.262	0.524							310	0.439
54	0.345	0.685							275	0.447

Span (inches)	UNIFORM LOAD in lb/ft ²								Max Load (lb/ft ²)	Apparent EI x 10 ⁶ (lb-in ²)
	50	100	150	200	250	500	1000	2000		
12	0.002	0.005	0.007	0.009	0.011	0.023	0.046	0.091	2480	0.599
18	0.011	0.021	0.032	0.043	0.053	0.106	0.213	0.425	1425	0.486
24	0.033	0.066	0.098	0.131	0.164	0.328			825	0.494
30	0.077	0.154	0.230	0.307	0.384				536	0.478
36	0.168	0.336	0.504						310	0.549
42	0.323	0.645							250	0.448
48	0.537									0.439

Properties Per Foot of Width	# of Bars	Load Bar Width	Bar Centers	Weight/sq ft
A = 2.47 in ² I = 0.16 in ⁴ S = 0.34 in ³	8	0.25"	0.75"	4.06

1 1/2" x 3/4" x 3/4"
Square Grid
1 1/2" Thick
44% Open

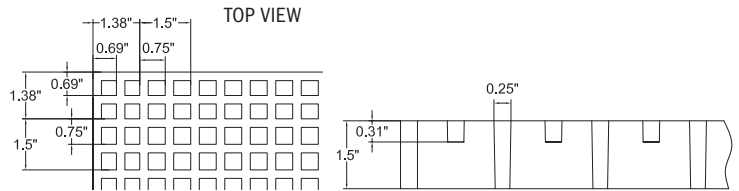

Span (inches)	CONCENTRATED LOAD in lb/ft of width								Max Load (lb/ft)	Apparent EI x 10 ⁶ (lb-in ²)
	50	100	150	200	250	500	1000	2000		
12	0.002	0.003	0.005	0.006	0.008	0.016	0.032	0.063	3090	1.14
18	0.004	0.009	0.013	0.017	0.021	0.043	0.085	0.170	2060	1.43
24	0.009	0.018	0.026	0.035	0.044	0.088	0.176	0.352	1545	1.64
30	0.016	0.032	0.048	0.064	0.080	0.160	0.321	0.642	1236	1.75
36	0.027	0.053	0.080	0.106	0.133	0.266	0.532		1030	1.83
42	0.041	0.083	0.124	0.165	0.207	0.413			883	1.87
48	0.060	0.121	0.181	0.242	0.302	0.605			773	1.90
54	0.085	0.170	0.255	0.339	0.424				687	1.93
60	0.116	0.232	0.347	0.463	0.579				618	1.94

Span (inches)	UNIFORM LOAD in lb/ft ²								Max Load (lb/ft ²)	Apparent EI x 10 ⁶ (lb-in ²)
	50	100	150	200	250	500	1000	2000		
12	<0.001	0.002	0.003	0.004	0.005	0.010	0.020	0.039	6180	1.14
18	0.004	0.008	0.012	0.016	0.020	0.040	0.080	0.159	2747	1.43
24	0.011	0.022	0.033	0.044	0.055	0.110	0.220		1545	1.64
30	0.025	0.050	0.075	0.100	0.125	0.251	0.502		989	1.75
36	0.050	0.100	0.149	0.199	0.249	0.498			687	1.83
42	0.090	0.181	0.271	0.362	0.452				505	1.87
48	0.151	0.302	0.454	0.605					386	1.90
54	0.239	0.477							305	1.93
60	0.362								247	1.94

Properties Per Foot of Width	# of Bars	Load Bar Width	Bar Centers	Weight/sq ft
A = 3.29 in ² I = 0.74 in ⁴ S = 0.90 in ³	8	0.25"	0.75"	4.75

1 1/8" x 1 1/2" x 1 1/2"
Square Grid
1 1/8" Thick
Covered

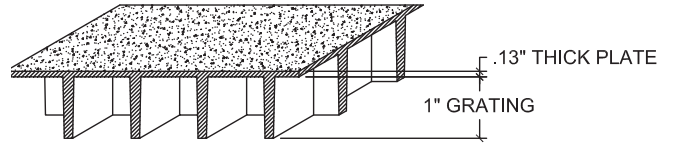
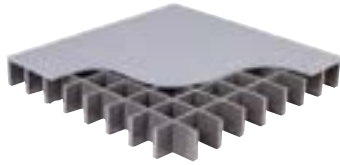

Span (inches)	CONCENTRATED LOAD in lb/ft of width								Max Load (lb/ft)	Apparent EI x 10 ⁶ (lb-in ²)
	50	100	150	200	250	500	1000	2000		
12	0.006	0.011	0.017	0.023	0.029	0.057	0.114		1189	0.31
18	0.018	0.035	0.053	0.071	0.089	0.177			934	0.34
24	0.040	0.080	0.120	0.160	0.199	0.399			668	0.36
30	0.076	0.152	0.228	0.304	0.380				534	0.37
36	0.128	0.256	0.384	0.512	0.640				360	0.38

Span (inches)	UNIFORM LOAD in lb/ft ²								Max Load (lb/ft ²)	Apparent EI x 10 ⁶ (lb-in ²)
	50	100	150	200	250	500	1000	2000		
12	0.004	0.007	0.011	0.014	0.018	0.036	0.071	0.143	2378	0.31
18	0.017	0.033	0.050	0.066	0.083	0.166	0.332		1245	0.34
24	0.050	0.100	0.150	0.199	0.249	0.498			668	0.36
30	0.119	0.237	0.356	0.475	0.593				427	0.37
36	0.240	0.480							240	0.38
42	0.431								205	0.39

Properties Per Foot of Width	# of Bars	Load Bar Width	Bar Centers	Weight/sq ft
A = 1.79 in ² I = 0.15 in ⁴ S = 0.30 in ³	8	0.25"	1.5"	2.73

1 5/8" x 1 1/2" x 1 1/2"
Square Grid
1 5/8" Thick
Covered

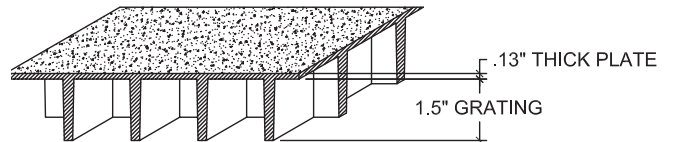
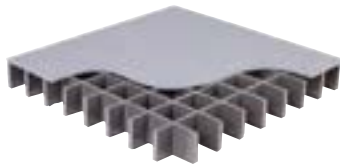

Span (inches)	CONCENTRATED LOAD in lb/ft of width								Max Load (lb/ft)	Apparent EI x 10 ⁶ (lb-in ²)
	50	100	150	200	250	500	1000	2000		
12	0.002	0.005	0.007	0.009	0.011	0.023	0.045	0.090	2041	0.80
18	0.005	0.011	0.016	0.022	0.027	0.055	0.109		1360	1.11
24	0.012	0.023	0.035	0.046	0.058	0.115	0.230		1021	1.25
30	0.021	0.043	0.064	0.086	0.107	0.214			816	1.31
36	0.036	0.072	0.108	0.144	0.180	0.360			680	1.35
42	0.056	0.113	0.169	0.225	0.282	0.563			583	1.37
48	0.084	0.167	0.251	0.334	0.418				510	1.38
54	0.119	0.238	0.357	0.476	0.594				453	1.38

Span (inches)	UNIFORM LOAD in lb/ft ²								Max Load (lb/ft ²)	Apparent EI x 10 ⁶ (lb-in ²)
	50	100	150	200	250	500	1000	2000		
12	0.001	0.003	0.004	0.006	0.007	0.014	0.028	0.057	4082	0.80
18	0.005	0.010	0.015	0.021	0.026	0.051	0.103		1813	1.11
24	0.014	0.029	0.043	0.058	0.072	0.144	0.288		1021	1.25
30	0.033	0.067	0.100	0.134	0.167	0.334			653	1.31
36	0.067	0.135	0.202	0.270	0.337				453	1.35
42	0.123	0.246	0.370	0.493	0.616				333	1.37
48	0.209	0.417	0.626						255	1.38
54	0.334	0.669							201	1.38

Properties Per Foot of Width	# of Bars	Load Bar Width	Bar Centers	Weight/sq ft
A = 2.73 in ² I = 0.49 in ⁴ S = 0.65 in ³	8	0.25"	1.5"	5.17



High Load Capacity Molded Grating (HLC)



High Load Capacity (HLC) molded grating is high-strength, corrosion-resistant and low-maintenance – just like our molded grating products. Plus, it's engineered to carry higher loads than traditional grating. Our molded HLC grating is available in 4' x 6' panels with 1½" and 2" thicknesses and comes in GPFR, IFR and VFR resin systems in standard gray

Available Resin Systems

HLC molded grating is available in three resin systems, each providing different levels of corrosion protection. All three resin systems meet Class 1 Flame Spread Rating per ASTM E-84 test standards.

GPFR: A general-purpose orthophthalic polyester resin system that offers good corrosion resistance at an economical price.

IFR: A premium-grade isophthalic polyester resin system that provides excellent corrosion protection.

VFR: A vinyl ester resin system that provides the highest level of corrosion protection.

APPLICATIONS

- Flooring, platforms and ramps
- Storage areas
- Assembly lines
- Long-span walkways
- Trench covers with vehicular traffic

FEATURES

- High strength
- Corrosion resistant
- Low conductivity
- Fire retardant
- Low maintenance

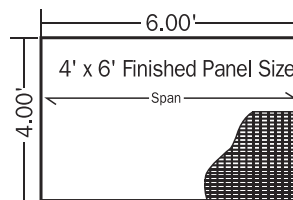

NOTE: Load carrying bars are oriented to run in the 6' dimension of the panel. Panels furnished with closed bars all sides.

Allowable Spans for Vehicular Loads	Wheel Load (lb) (½ Axle Load + 30% Impact)	Load Distribution		Allowable Span in Inches	
		Parallel to Axle	Perpendicular to Axle	1.5" Deep HLC Molded Grating	2" Deep HLC Molded Grating
AASHTO Standard Truck 32,000 lb Axle Load - Dual Wheels (*formerly AASHTO H-20)	20,800	20" + 4"	8"	1'-2"	1'-5"
Automobile Traffic 5,000 lb Vehicle - 1,500 lb Load 55% Drive Axle Load	2,220	8" + 4"	8"	2'-2"	2'-8"
5 Ton Capacity Forklift 14,400 lb Vehicle - 24,400 lb Total Load 85% Drive Axle Load	13,480	11" + 4"	11"	1'-1"	1'-5"
3 Ton Capacity Forklift 9,800 lb Vehicle - 15,800 lb Total Load 85% Drive Axle Load	8,730	7" + 4"	7"	1'-0"	1'-4"
1 Ton Capacity Forklift 4,200 lb Vehicle - 6,200 lb Total Load 85% Drive Axle Load	3,425	4" + 4"	4"	1'-7"	2'-1"

NOTES: Allowable Spans for Vehicular Loads

1. Load is carried by the grating load bars immediately under wheel + four additional load bars adjacent to wheel.
2. Allowable Span is based on a 0.25" maximum deflection and a Factor of Safety of 3.0. Other criteria may be required by certain construction codes. Check code requirements to determine design criteria.
3. ALLOWABLE SPAN IS STRONGLY DEPENDENT ON WHEEL WIDTH AND VEHICLE WEIGHT/LOAD CAPACITY. If your application varies from the values given on this table, contact us for application assistance.
4. Load based on the AASHTO Standard Truck Load as defined in AASHTO LRFD Bridge Design Specifications, 2nd Ed. This does not imply that the allowable span meets the deflection requirements of this specification.

High Load Capacity Molded Grating Load and Deflection Data

CONCENTRATED LOAD

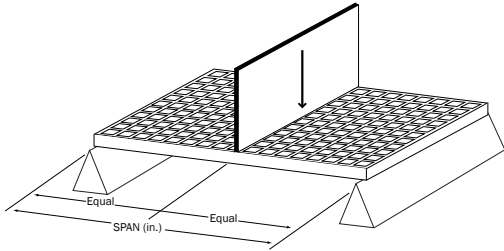

UNIFORM LOAD

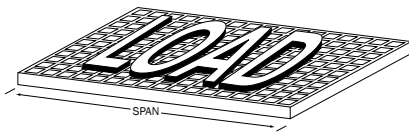

- The following tables were developed in accordance with the test method developed by the Fiberglass Grating Manufacturers Council (FGMC) of the American Composites Manufacturers Association (ACMA) for the Fiberglass Grating Standard.
- The designer should not exceed MAXIMUM RECOMMENDED load at any time. MAXIMUM LOAD represents a 4:1 factor of safety on ULTIMATE CAPACITY. ULTIMATE CAPACITY represents MAX LOAD observed at initial fracture.
- Walking loads for maintenance traffic are typically a live load of 50 PSF. Deflections for worker comfort are typically limited to 0.375" ($\frac{3}{8}$ " or SPAN divided by 120 under full live load. For a firmer feel under full live load or a line load 250 lb/ft of width, limit deflections to 0.25" ($\frac{1}{4}$ " or SPAN divided by 200.
- The loads represented are for STATIC LOAD CONDITIONS at ambient temperature. Deflections for impact loads or dynamic loads will MULTIPLY the deflections shown by 2. Long term loads will result in added deflection due to creep in the material and will require higher factors of safety to ensure acceptable performance.
- Deflections are limited to 0.5" ($\frac{1}{2}$ " as recommended by the Fiberglass Grating Manufacturers Council of the American Composites Manufacturers Association.

**1½" x 1" x 2" HLC
Rectangular Grid
1½" Thick
48% Open**

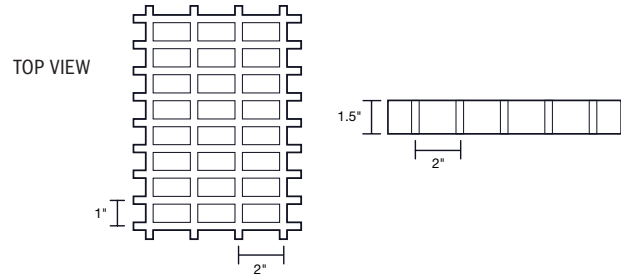

Span (inches)	CONCENTRATED LOAD in lb/ft of width							Max Load (lb/ft)
	200	500	1000	2000	3000	4000	5000	
18	<0.01	0.02	0.04	0.07	0.11	0.15	0.19	28,047
24	0.02	0.04	0.09	0.17	0.26	0.34	0.44	20,430
36	0.06	0.14	0.28					13,620
42	0.09	0.22	0.44					11,619

Span (inches)	UNIFORM LOAD in lb/ft²						Max Load (lb/ft²)
	200	400	500	600	700	800	
18	<0.01	0.01	0.02	0.02	0.02	0.03	36,000
24	0.02	0.04	0.05	0.06	0.08	0.09	20,390
36	0.10	0.21	0.26	0.31	0.37	0.42	8,814
42	0.19	0.39	0.48				6,550

Properties Per Foot of Width	# of Bars	Load Bar Width	Bar Centers	Weight/sq ft
A=7.2 in² I=1.35 in⁴ S=1.75	12	T-.43 / B-.35	1"	6.21

**2" x 1" x 2" HLC
Rectangular Grid
2" Thick
48% Open**

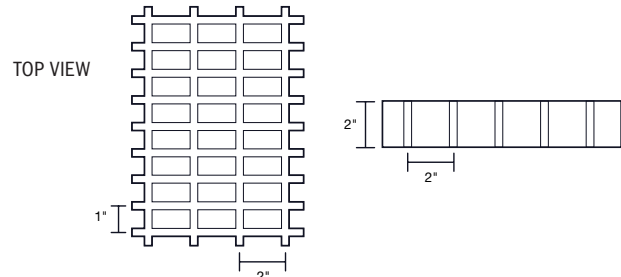

Span (inches)	CONCENTRATED LOAD in lb/ft of width							Max Load (lb/ft)
	200	500	1000	2000	3000	4000	5000	
18	<0.01	0.01	0.03	0.05	0.07	0.10	0.13"	32,651
24	0.02	0.03	0.06	0.11	0.17	0.22	0.27	27,245
36	0.04	0.09	0.17	0.34	0.51			18,130
42	0.05	0.13	0.26					15,525

Span (inches)	UNIFORM LOAD in lb/ft²						Max Load (lb/ft²)
	200	400	500	600	700	800	
18	<0.01	0.01	0.01	0.01	0.01	0.01	43,494
24	0.01	0.02	0.03	0.04	0.04	0.05	27,195
36	0.06	0.12	0.15	0.18	0.21	0.24	8,795
42	0.11	0.22	0.28	0.33	0.39	0.44	8,795

Properties Per Foot of Width	# of Bars	Load Bar Width	Bar Centers	Weight/sq ft
A=7.2 in² I=1.35 in⁴ S=1.75	12	T-.47 / B-.35	1"	8.4



Pultruded Grating

Pultruded grating supports heavier loads and longer spans than comparably sized molded grating. It's ideal for demanding applications ranging from ADA-compliant walkways to heavy-duty vehicular traffic.

Strong, Lightweight and Corrosion-Resistant

Pultruded grating has the strength of steel, but it won't corrode like steel can.

Safer Walking Surface

A quartz grit anti-slip epoxy coating enhances traction.

Support and Stability

Cross-rods and bearing bars lock mechanically for maximum unidirectional strength.

Easy Fabrication

Panels are lightweight, easy to transport, and can be cut and fabricated using standard hand tools.

Extended Life

The coated resin surface increases resistance to chemical corrosion and continuous UV exposure.

Stress Resistance

Continuous glass rovings resist tension, compression and bending while providing longitudinal strength. Continuous glass mat increases transverse strength and resistance to impact.



Available Resin Systems

Pultruded grating is available in two resin systems, each providing different levels of corrosion protection. Both resin systems meet Class 1 Flame Spread Rating per ASTM E-84 test standards.

IFR: A premium-grade isophthalic polyester resin system that provides excellent corrosion protection. Standard colors: Yellow and Gray.

VFR: A vinylester resin system that provides the highest level of corrosion protection. Standard colors: Yellow and Gray.

APPLICATIONS

- Floor systems
- Walkways
- Work platforms
- Stairs
- Ramps
- Trench covers
- Catwalks

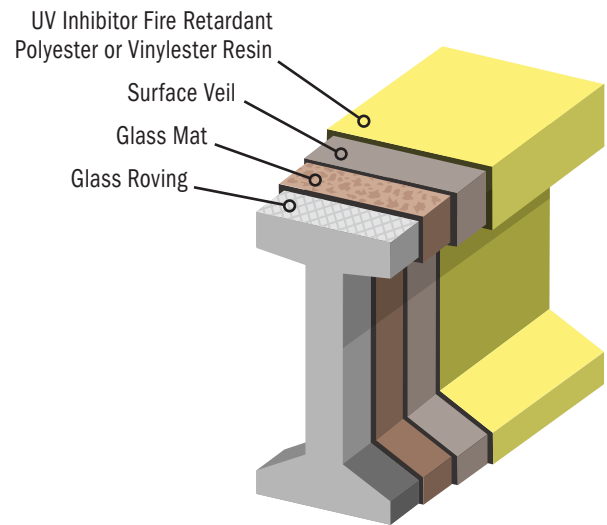

Pultruded Grating

Standard Dimensions

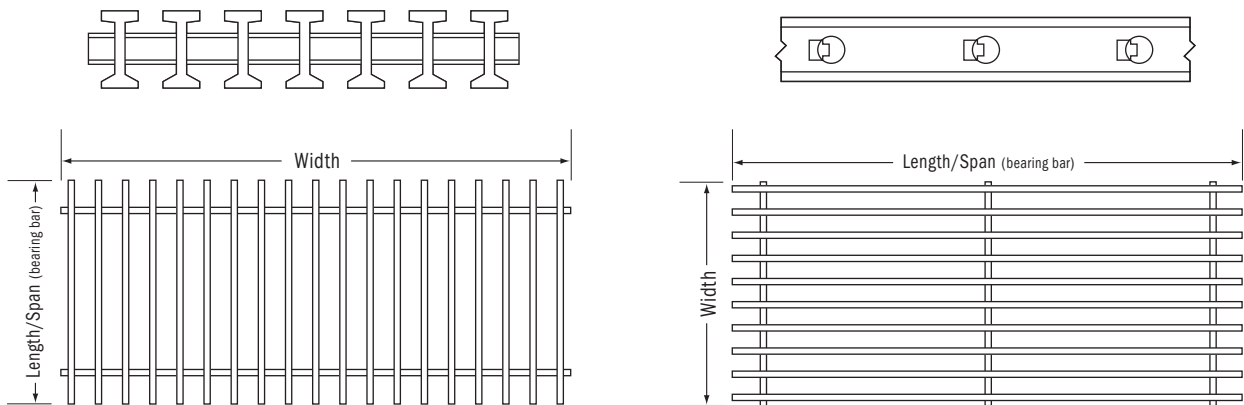

Available Panel Sizes*

3' wide x 20' long	4' wide x 20' long
3' wide x 24' long	4' wide x 24' long

*Note: Not all panel sizes are stocked in every resin series and color. Check website for availability.

Pultruded Grating Load and Deflection Data

CONCENTRATED LOAD

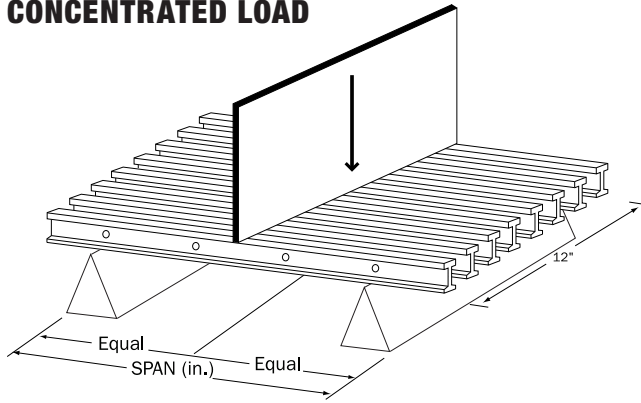

UNIFORM LOAD

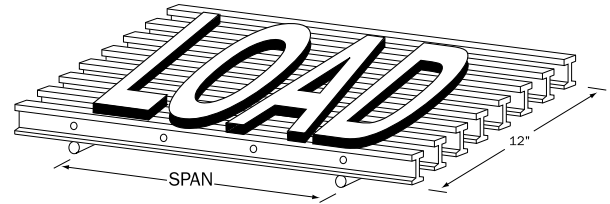

1. The following tables were developed in accordance with the test method developed by the Fiberglass Grating Manufacturers Council (FGMC) of the American Composites Manufacturers Association (ACMA) for the Fiberglass Grating Standard.
2. The designer should not exceed MAXIMUM RECOMMENDED load at any time. ULTIMATE CAPACITY represents MAX LOAD observed at initial fracture.
3. Walking loads for maintenance traffic are typically a live load of 50 PSF. Deflections for worker comfort are typically limited to 0.375" ($\frac{3}{8}$ ") or SPAN divided by 120 under full live load. For a firmer feel under full live load or a line load 250 lb/ft of width, limit deflections to 0.25" ($\frac{1}{4}$ ") or SPAN divided by 200.
4. The loads represented are for STATIC LOAD CONDITIONS at ambient temperature. Deflections for impact loads or dynamic loads will MULTIPLY the deflections shown by 2. Long term loads will result in added deflection due to creep in the material and will require higher factors of safety to ensure acceptable performance.
- 5 Deflections are limited to 0.5" ($\frac{1}{2}$ ") as recommended by the Fiberglass Grating Manufacturers Council of the American Composites Manufacturers Association.

T 20-50
T Bearing Bar
 2" Thick
 50% Open

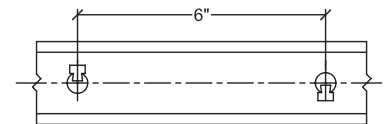
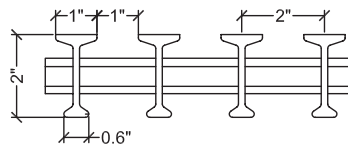

Span (inches)	CONCENTRATED LOAD in lb/ft of width								Max Load (lb/ft)	Apparent EI x 10 ⁶ (lb-in ²)
	50	100	150	200	250	500	1000	2000		
12	0.001	0.002	0.003	0.004	0.005	0.010	0.020	0.040	13302	1.80
18	0.001	0.003	0.004	0.006	0.007	0.015	0.029	0.059	8868	4.15
24	0.002	0.005	0.007	0.009	0.012	0.023	0.047	0.093	6651	6.17
30	0.004	0.008	0.011	0.015	0.019	0.038	0.077	0.153	5321	7.35
36	0.006	0.012	0.018	0.024	0.031	0.061	0.122	0.245	4434	7.95
42	0.009	0.019	0.028	0.037	0.046	0.093	0.186	0.372	3801	8.31
48	0.013	0.027	0.040	0.054	0.067	0.135	0.269	0.539	3326	8.55
54	0.019	0.038	0.057	0.076	0.095	0.190	0.379		2956	8.65
60	0.026	0.051	0.077	0.103	0.129	0.257	0.514		2660	8.75
66	0.034	0.068	0.102	0.136	0.171	0.341	0.682		2419	8.78
72	0.044	0.088	0.133	0.177	0.221	0.442			2217	8.80

Span (inches)	UNIFORM LOAD in lb/ft ²								Max Load (lb/ft ²)	Apparent EI x 10 ⁶ (lb-in ²)
	50	100	150	200	250	500	1000	2000		
12	0.001	0.001	0.002	0.002	0.003	0.006	0.012	0.025	23936	1.80
18	0.001	0.003	0.004	0.005	0.007	0.014	0.027	0.055	8624	4.15
24	0.003	0.006	0.009	0.012	0.015	0.029	0.058	0.117	6468	6.17
30	0.006	0.012	0.180	0.024	0.030	0.060	0.120	0.239	4242	7.35
36	0.011	0.023	0.034	0.046	0.057	0.115	0.229	0.458	2946	7.95
42	0.020	0.041	0.061	0.081	0.102	0.203	0.407		2153	8.31
48	0.034	0.067	0.101	0.135	0.168	0.337	0.674		1672	8.55
54	0.053	0.107	0.160	0.213	0.267	0.533			1310	8.65
60	0.080	0.161	0.241	0.321	0.402				1062	8.75
66	0.117	0.234	0.352	0.469	0.586				881	8.78
72	0.166	0.331	0.497	0.663					740	8.80

Properties Per Foot of Width	# of Bars	Load Bar Depth	Bar Centers	Weight/sq ft
A = 3.23 in ² I = 1.58 in ⁴ S _x = 1.98 in ³ S _y = 1.32 in ³	6	2"	2"	3.43

I 15-40
I Bearing Bar
 1½" Thick
 40% Open

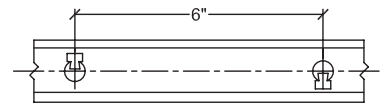
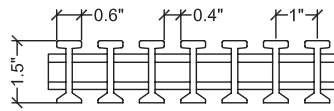

Span (inches)	CONCENTRATED LOAD in lb/ft of width								Max Load (lb/ft)	Apparent EI x 10 ⁶ (lb-in ²)
	50	100	150	200	250	500	1000	2000		
12	0.001	0.001	0.002	0.002	0.003	0.006	0.012	0.024	14034	3.00
18	0.001	0.002	0.004	0.005	0.006	0.012	0.025	0.050	9356	4.88
24	0.002	0.005	0.007	0.010	0.012	0.024	0.049	0.098	7017	5.90
30	0.004	0.009	0.013	0.018	0.022	0.044	0.088	0.176	5614	6.40
36	0.007	0.015	0.022	0.029	0.036	0.073	0.146	0.292	4678	6.66
42	0.011	0.023	0.034	0.046	0.057	0.114	0.229	0.457	4010	6.75
48	0.017	0.034	0.051	0.068	0.085	0.169	0.338	0.677	3509	6.81
54	0.024	0.048	0.072	0.096	0.120	0.240	0.480		3119	6.83
60	0.033	0.066	0.099	0.131	0.164	0.328	0.657		2807	6.85
66	0.044	0.087	0.131	0.174	0.218	0.436			2552	6.87
72	0.057	0.113	0.170	0.226	0.283	0.565			2339	6.88

Span (inches)	UNIFORM LOAD in lb/ft ²								Max Load (lb/ft ²)	Apparent EI x 10 ⁶ (lb-in ²)
	50	100	150	200	250	500	1000	2000		
12	<0.001	0.001	0.001	0.001	0.002	0.004	0.007	0.015	21051	3.00
18	0.001	0.002	0.004	0.005	0.006	0.012	0.023	0.047	14559	4.88
24	0.003	0.006	0.009	0.012	0.015	0.031	0.061	0.122	7136	5.90
30	0.007	0.014	0.021	0.027	0.034	0.069	0.137	0.275	4405	6.40
36	0.014	0.027	0.041	0.055	0.068	0.137	0.274	0.547	3161	6.66
42	0.025	0.050	0.075	0.100	0.125	0.250	0.500		2292	6.75
48	0.042	0.085	0.127	0.169	0.211	0.423			1746	6.81
54	0.068	0.135	0.203	0.270	0.338	0.675			1387	6.83
60	0.103	0.205	0.308	0.411	0.513				1124	6.85
66	0.150	0.300	0.450	0.599					928	6.87
72	0.212	0.424	0.636						779	6.88

Properties Per Foot of Width	# of Bars	Load Bar Depth	Bar Centers	Weight/sq ft
A = 4.66 in ² I = 1.32 in ⁴ S = 1.76 in ³	12	1.5"	1"	4.22

I 10-60
I Bearing Bar
 1" Thick
 60% Open

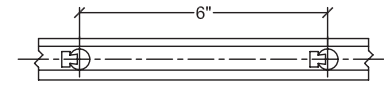
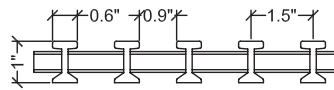

Span (inches)	CONCENTRATED LOAD in lb/ft of width								Max Load (lb/ft)	Apparent EI x 10 ⁶ (lb-in ²)
	50	100	150	200	250	500	1000	2000		
12	0.002	0.003	0.005	0.007	0.008	0.016	0.033	0.065	5755	1.10
18	0.004	0.009	0.013	0.018	0.022	0.044	0.088	0.176	3850	1.38
24	0.009	0.019	0.028	0.037	0.047	0.094	0.187	0.374	2888	1.54
30	0.017	0.035	0.052	0.069	0.086	0.173	0.345	0.690	2310	1.63
36	0.029	0.059	0.088	0.117	0.146	0.293	0.586		1925	1.66
42	0.046	0.092	0.138	0.184	0.230	0.459			1650	1.68
48	0.068	0.136	0.203	0.271	0.339	0.678			1444	1.70
54	0.095	0.191	0.286	0.381	0.477				1283	1.72
60	0.129	0.259	0.388	0.517	0.647				1155	1.74
66	0.171	0.342	0.513	0.685					1050	1.75
72	0.221	0.442	0.663						962	1.76

Span (inches)	UNIFORM LOAD in lb/ft ²								Max Load (lb/ft ²)	Apparent EI x 10 ⁶ (lb-in ²)
	50	100	150	200	250	500	1000	2000		
12	0.001	0.002	0.003	0.004	0.005	0.010	0.020	0.041	7944	1.10
18	0.004	0.008	0.012	0.017	0.021	0.041	0.083	0.165	5296	1.38
24	0.012	0.023	0.035	0.047	0.058	0.117	0.234	0.468	2935	1.54
30	0.027	0.054	0.081	0.108	0.135	0.270	0.539		1845	1.63
36	0.055	0.110	0.165	0.220	0.274	0.549			1281	1.66
42	0.100	0.201	0.301	0.402	0.502				943	1.68
48	0.169	0.339	0.508	0.678					721	1.70
54	0.268	0.536							571	1.72
60	0.404								514	1.74

Properties Per Foot of Width	# of Bars	Load Bar Depth	Bar Centers	Weight/sq ft
A = 2.44 in ² I = 0.31 in ⁴ S = 0.62 in ³	8	1"	1.5"	2.47

I 15-60
I Bearing Bar
 1½" Thick
 60% Open

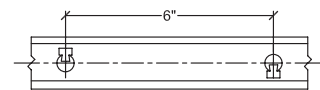
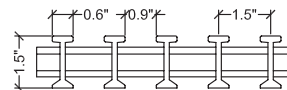

Span (inches)	CONCENTRATED LOAD in lb/ft of width								Max Load (lb/ft)	Apparent EI x 10 ⁶ (lb-in ²)
	50	100	150	200	250	500	1000	2000		
12	0.001	0.002	0.003	0.004	0.005	0.009	0.018	0.036	8958	1.99
18	0.002	0.004	0.006	0.008	0.009	0.019	0.038	0.075	5972	3.23
24	0.004	0.007	0.011	0.015	0.018	0.037	0.074	0.147	4479	3.91
30	0.007	0.013	0.020	0.027	0.033	0.066	0.133	0.265	3853	4.24
36	0.011	0.022	0.033	0.044	0.055	0.110	0.220	0.441	2986	4.41
42	0.017	0.035	0.052	0.069	0.086	0.173	0.345	0.691	2559	4.47
48	0.026	0.051	0.077	0.102	0.128	0.255	0.511		2240	4.51
54	0.036	0.073	0.109	0.145	0.181	0.363			1991	4.52
60	0.050	0.099	0.149	0.198	0.248	0.496			1792	4.54
66	0.066	0.132	0.197	0.263	0.329	0.658			1629	4.55
72	0.085	0.171	0.256	0.341	0.427				1493	4.56

Span (inches)	UNIFORM LOAD in lb/ft ²								Max Load (lb/ft ²)	Apparent EI x 10 ⁶ (lb-in ²)
	50	100	150	200	250	500	1000	2000		
12	0.001	0.001	0.002	0.002	0.003	0.006	0.011	0.023	10524	1.99
18	0.002	0.004	0.005	0.007	0.009	0.018	0.035	0.070	7016	3.23
24	0.005	0.009	0.014	0.018	0.023	0.046	0.092	0.184	4585	3.91
30	0.010	0.021	0.031	0.041	0.052	0.104	0.207	0.415	2831	4.24
36	0.021	0.041	0.062	0.083	0.103	0.207	0.413		2006	4.41
42	0.038	0.076	0.113	0.151	0.189	0.378			1454	4.47
48	0.064	0.128	0.192	0.255	0.319	0.639			1117	4.51
54	0.102	0.204	0.306	0.408	0.510				885	4.52
60	0.155	0.310	0.465	0.620					717	4.54
66	0.226	0.453	0.679						592	4.55
72	0.320	0.640							498	4.56

Properties Per Foot of Width	# of Bars	Load Bar Depth	Bar Centers	Weight/sq ft
A = 3.11 in ² I = 0.88 in ⁴ S = 1.17 in ³	8	1.5"	1.5"	2.97

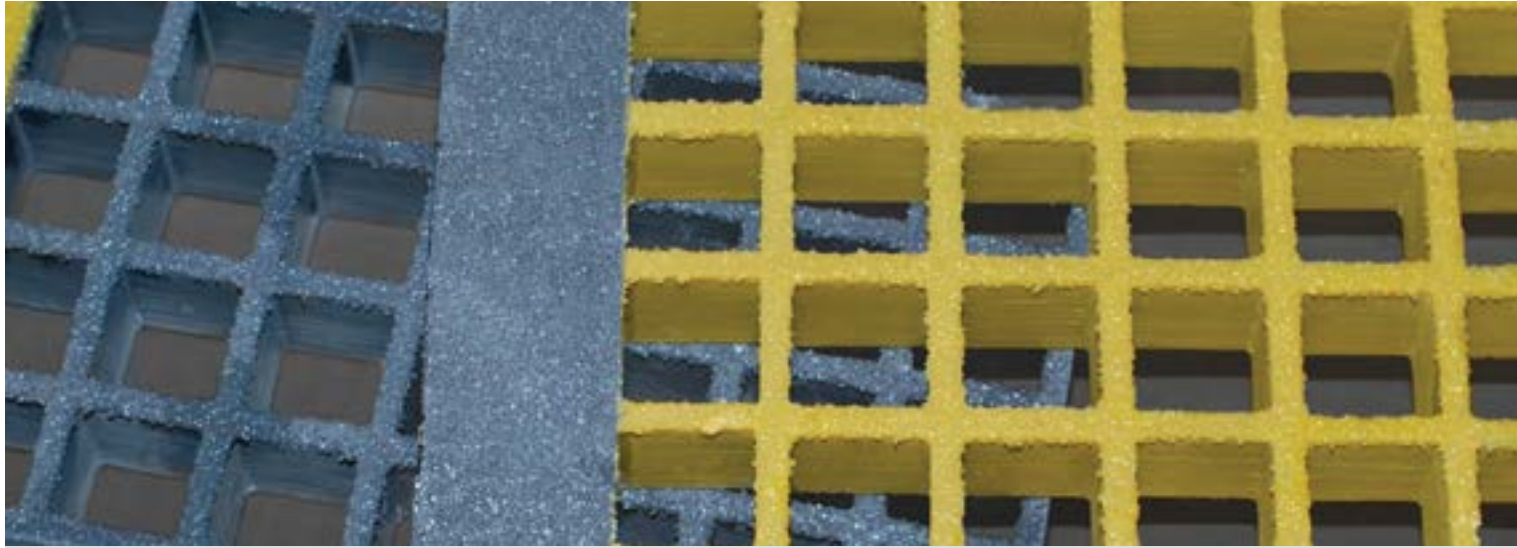

Molded & Pultruded Stair Treads & Stair Tread Covers

Stair Treads

Our stair tread panels allow you to cut your own stair treads quickly and inexpensively for less waste and less cost. We stock molded stair treads in several sizes and configurations. Custom-fabricated sizes are available upon request.

We can also supply pultruded stair tread in stock sizes or made to order. These maintenance-free treads are engineered for strength, durability and corrosion resistance. Features include a non-skid surface and square tube nosing for high visibility. Our design is easy to fabricate and install on-site with basic tools.

Stair Tread Covers

FRP stair tread covers are a cost-effective option to improve stairway safety for your workers. All of our stair treads are made with corrosion-resistant, fire-retardant resin and have an anti-skid top surface.

Grating Fasteners

All grating must be fastened in place. We offer a variety of clips to complete your installation (see page 20).

Chemical Compatibility

See page 51 for a detailed table of chemical compatibility based on resin manufacturers' data, including maximum allowable concentrations and temperatures.



Molded Stair Tread



Pultruded Stair Tread



Stair Tread Cover

Stair Treads and Covers Load and Deflection Data

Molded Grating Stair Treads

1 1/2" x 1 1/2" x 6"

1 1/2" deep w/1 1/2" x 6" mesh size			
Span (inches)	250 lb	500 lb	Max lb
18	0.04	0.07	7887
24	0.06	0.12	6084
30	0.12	0.25	4907
36	0.23	0.51	3302
42	0.25	0.56	3480

1 1/2" x 1 1/2" x 1 1/2"

1 1/2" deep w/1 1/2" x 1 1/2" mesh size			
Span (inches)	250 lb	500 lb	Max lb
18	0.03	0.06	9644
24	0.07	0.13	6848
30	0.09	0.18	5555
36	0.15	0.31	4666
42	0.23	0.48	4063

Pultruded Grating Stair Treads

I 15-60

1 1/2" deep I-beam w/60% open area			
Span (inches)	250 lb	500 lb	Max lb
18	0.02	0.03	12187
24	0.03	0.05	11424
30	0.04	0.07	10256
36	0.06	0.11	8157
42	0.08	0.16	7010

T 20-50

2" deep T-beam w/50% open area			
Span (inches)	250 lb	500 lb	Max lb
18	0.01	0.03	13230
24	0.03	0.05	11962
30	0.03	0.05	12490
36	0.04	0.07	11297
42	0.05	0.09	11412

Deflection values are based on concentrated loads of 250 lb and 500 lb applied at the center of span. Span and deflection values are in inches. Max lb represents maximum experimental failure load.

1 1/2" x 1 1/2" x 6"
Molded Stair Tread
 24" x 144" Panel, 65% Open

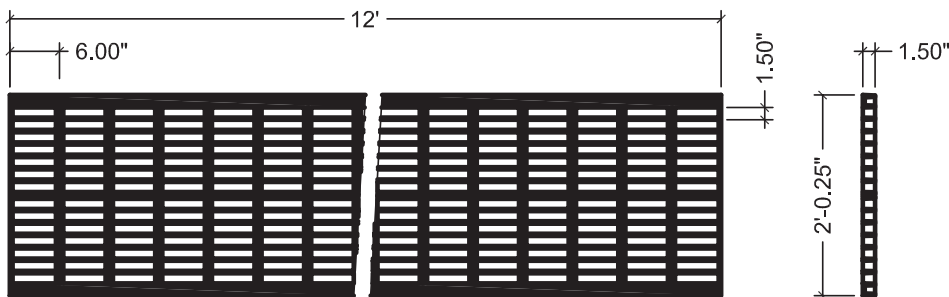

1 1/2" x 1 1/2" x 1 1/2"
Molded Stair Tread
 12" x 144" Panel, 68% Open

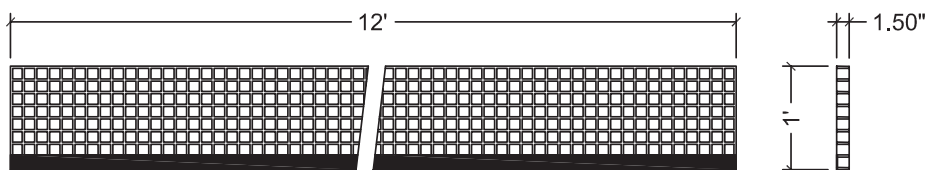
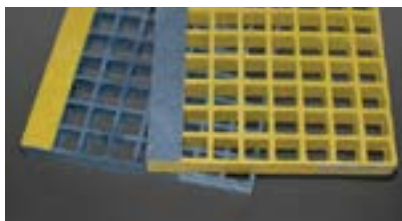

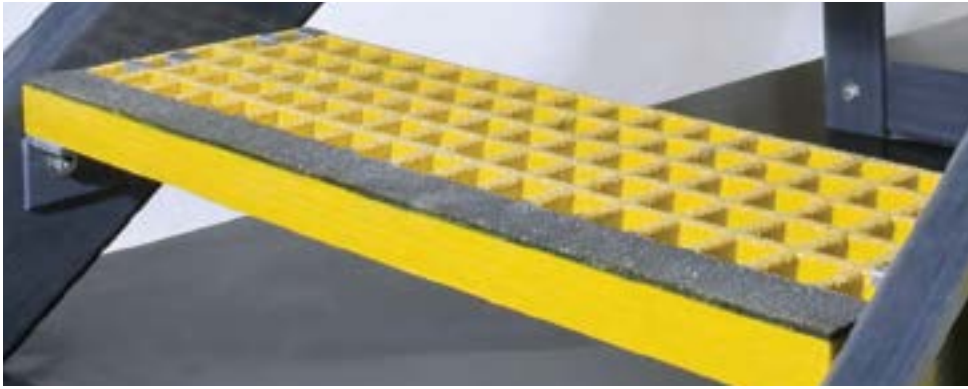

I 15-60
I Bearing Bar
Pultruded Stair Tread
 12" x 144" Panel, 60% Open

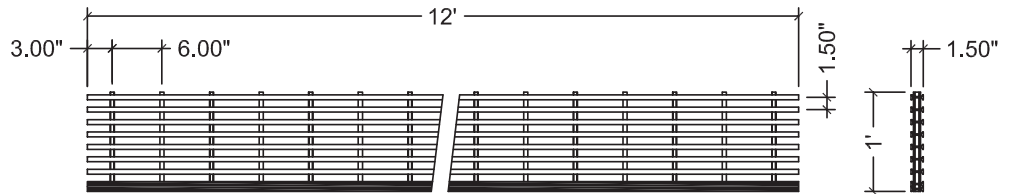

T 20-50
T Bearing Bar
Pultruded Stair Tread
 12" x 144" Panel, 50% Open

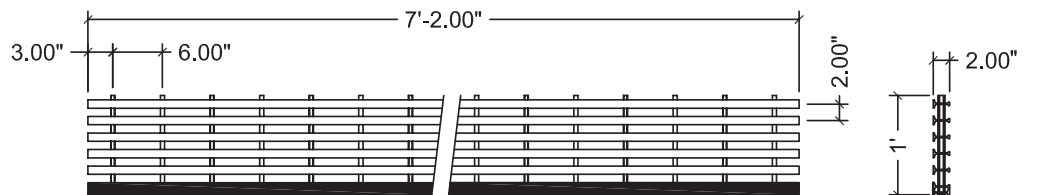

Stair Tread Cover



Cover Placement for Wood and Concrete Treads

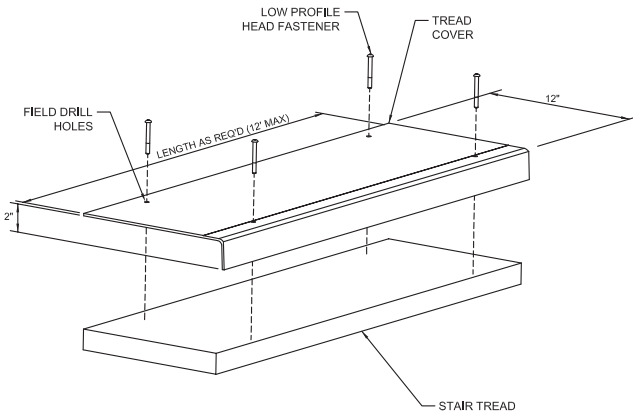

Cover Placement for Stair Tread Grating

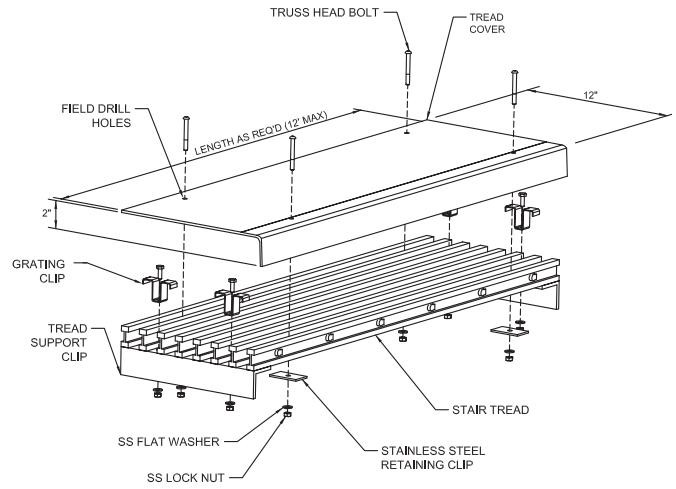

Fasteners

M Clip (Saddle Clip)

M clips are used to secure molded or pultruded grating panels to a support using two adjacent grating bars for a secure fit.



MOLDED PULTRUDED

W Clip (Washer Clip)

W clips are made specifically for plate or grating with plate on top. The length of the bolt should correspond with the height of the panel.



MOLDED PULTRUDED

L Clip (J Clip)

L clips are used to fasten molded or pultruded grating to a support bar for moderate loads.



MOLDED PULTRUDED

Additional Fasteners



C Clip (End Panel Clip)

C clips are used to join two ends of molded grating together. Clips should be placed every 2'-3' to meet industry requirements.



G Clips

G clips are designed to attach grating to any structural member flange, 0.75" or smaller in thickness, with no drilling required.



J Bolts

J bolts are used to secure grating to a support bar.



T Clips

T clips are used to fasten pultruded grating to a support frame.

Fastener Location Examples

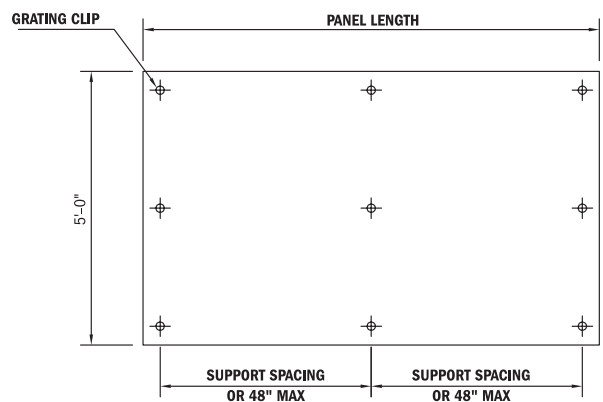
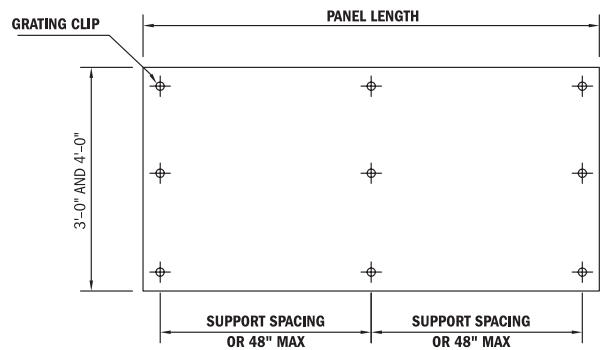
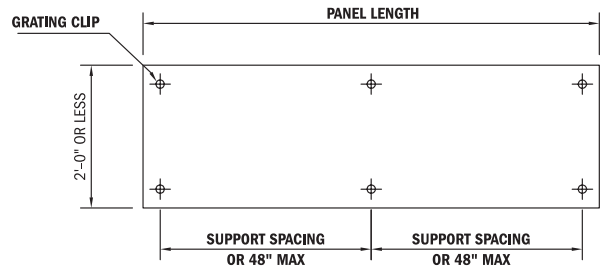

Provide a minimum of 1½" bearing surface per support.

Standard clip spacing is three clips per support per grating panel.

Standard clip spacing for 2'-0" or less in panel width is two clips per support per grating panel.

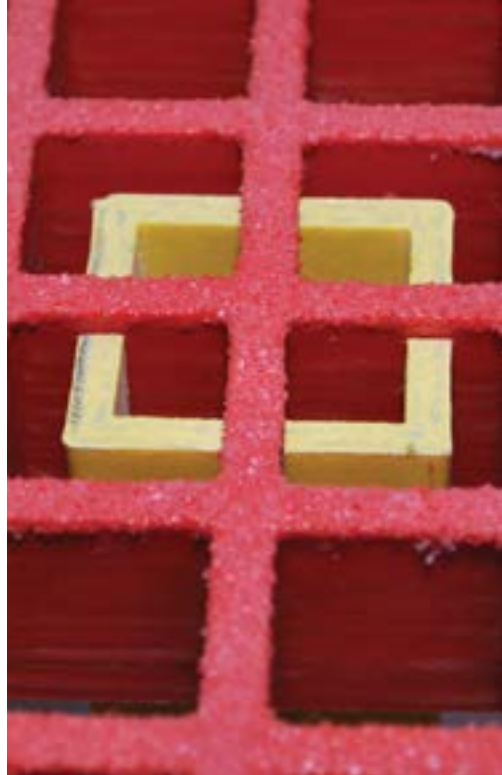

Grating Pedestals



We offer several pedestals for applications requiring elevated grating floor systems. Contact us for sizes and availability.



EXPLORE OUR FULL LINE OF FRP SOLUTIONS

We offer a wide variety of structural products made of fiberglass-reinforced polymer, including structural shapes, molded grating and pultruded grating. Our staff of skilled design, engineering and manufacturing professionals is dedicated to helping our customers maximize the benefits of FRP.

PRODUCTS

- Structural shapes
- Grating
- Decking
- Stairs and handrails
- Ladders and cages
- Fabricated structures

SERVICES

- Design and drafting
- Engineering
- Fabrication and CNC machining
- Secondary coating and painting
- Assembly and kitting
- In-house testing



STRUCTURAL FIBERGLASS

DEFI STRUCTURAL FIBERGLASS

PHONE: 800-949-3665 / 281-440-3665 | WEB: WWW.DEFIFIBERGLASS.COM

The photographs and/or drawings in this literature are for illustrative purposes only. While every reasonable effort has been made to ensure the accuracy of this data, we are not responsible for any errors or omissions contained on these pages. Please verify any information in question with a sales representative. We reserve the right to make changes in specifications without notice and without incurring obligation.